

3-Arm Caliper

710mm, 1000mm and 1500mm ranges

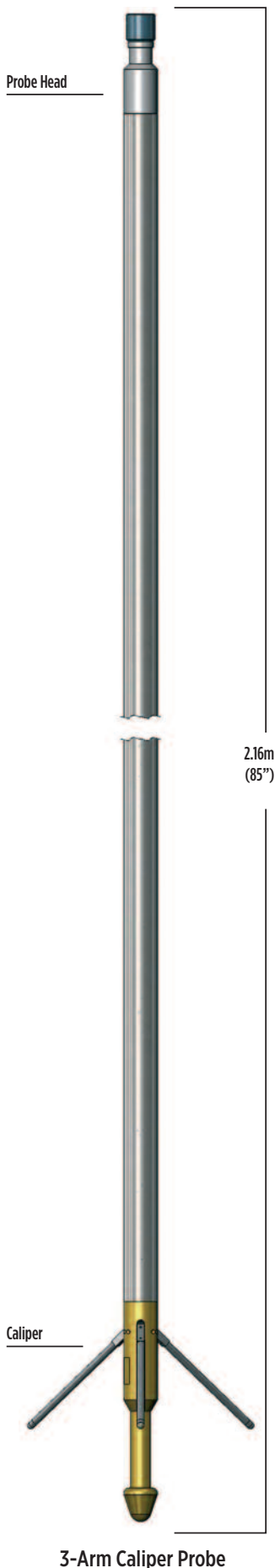

The 3-Arm Caliper probe provides a single continuous log of borehole diameter as recorded by three mechanically coupled arms in contact with the borehole wall.

710mm, 1000mm and 1500mm range calipers are available to suit a range of well diameters. The caliper is a useful first log to determine the borehole conditions before running more costly probes or those containing radioactive sources.

Principle of Measurement:

Opening and closing of the motor-driver caliper arms is by surface command, allowing the probe to run into the borehole with the arms retracted. Once opened, the spring-loaded arms respond to borehole diameter variations as the probe is raised up the borehole.

SPECIFICATION:

Features

- Small diameter for slim-hole operation
- Extension arms supplied as standard for 38mm version
- Optional natural-gamma measurement
- Optional casing collar locator

Measurements

- CCL (optional)
- Borehole volume (derived)
- Natural Gamma (optional)
- Borehole volume

Applications

- Minerals/Water/Engineering
- Location of borehole collapse or obstructions
- Cement volume calculations for grouting
- Identification of hard and soft lithology
- Location of cracks, fissures, caving, faulting, casing breaks
- Correction of other logs affected by borehole diameter

Operating Conditions

- Borehole type: open/cased; water/air-filled
- Centralisation: recommended in large holes
- Centralisation: recommended in inclined holes
- Recommended Logging Speed: 5m/min

Specifications

- Temperature: 0-70°C (extended ranges available)
- Max. pressure: 20MPa

3-Arm Caliper (710mm range)

- Diameter: 38mm
- Length: 2.18m-2.68m (depending on CCL and extended arms)
- Weight: 7.5kg
- Range: 40-300mm and 40-710mm

3-Arm Caliper (1000mm range)

- Diameter: 60mm
- Length: 2.83m
- Weight: 15kg
- Range: 65-1000mm

3-Arm Caliper (1500mm range)

- Diameter: 80mm
- Length: 3.14m
- Weight: 17.5kg
- Range: 100 - 1600mm

Part Numbers

- 1002035 3-Arm Caliper (710mm range) with arm extension kit and calibrator
- 1002037 - including natural gamma
- 1002041 3-Arm Caliper (1000mm range) with calibrator
- 1002052 3-Arm Caliper (1500mm range)

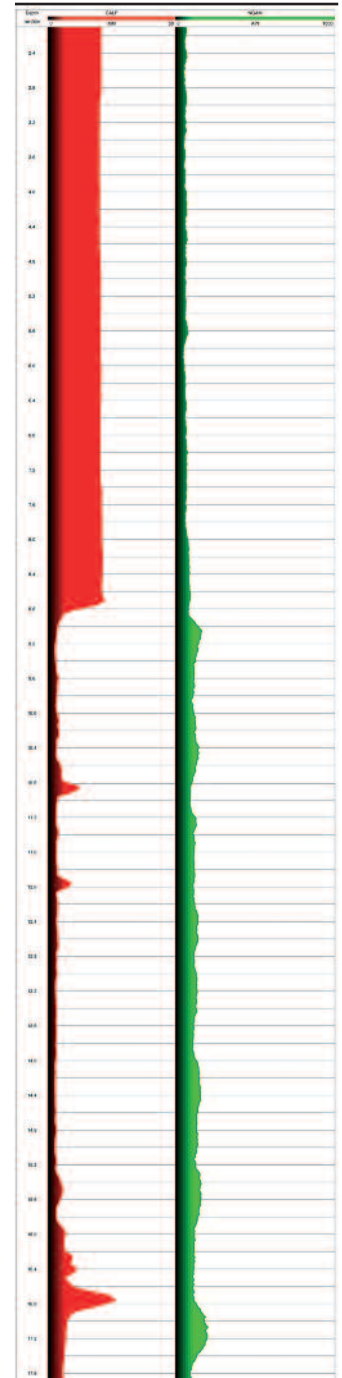

Example of logging data